

Graceful styling and two contemporary colors complement any utility room or basement. Durable construction provides carefree service year after year.

Caribbean 3

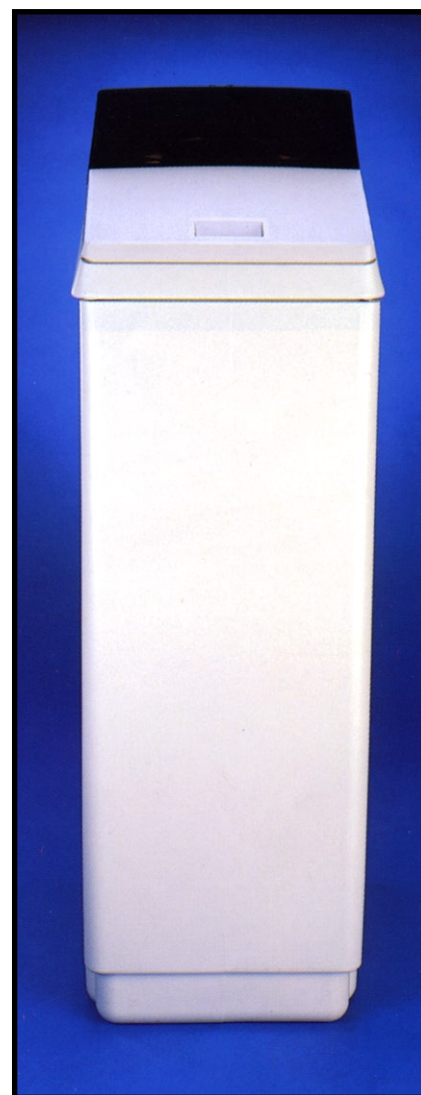

CONVENIENT - Brine compartment and valve are easily accessed for maintenance and service. Large salt storage capacity.

DURABLE - Heavy duty blow molded plastic cabinet and injection molded cover resist corrosion for long dependable service.

Caribbean 3

The Caribbean features a blow molded combination brine and softener cabinet with an injection molded salt lid and dust cover for exceptional appearance and strength. The Caribbean is available in Almond or White with dark brown (smoke) dust cover.

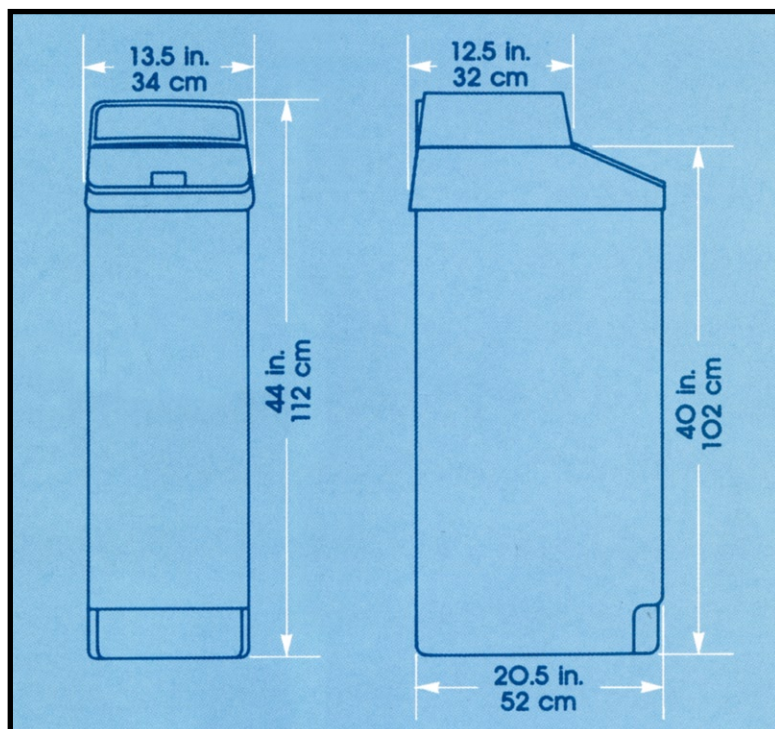

Features:

- Cabinet accommodates mineral tanks up to 10" x 35" high.
- Injection molded dust cover protects valve and controls.
- Patented baffle plate protects controls from corrosive salt fumes.
- Removable upper section provides easy access to controls and mineral tanks.
- Blow molded brine compartment resists corrosive salts for long, dependable service.
- Detachable salt lid provides access to brine compartment without removing the valve cover.
- Custom hot stamp covers are available. Please consult factory for specification.

ORDER NUMBER	DESCRIPTION	QTY/ CARTON	CARTON WEIGHT
G2714-01	Almond	1	20 lbs.
G2716-01	White	1	20 lbs.