

**Clack Order No. V3007-13LF**

**Description: WS1 Fitting 1" Brass SharkBite LF Assembly**

Drawing No.	Order No.	Description	Quantity
1	V3151	WS1 Nut 1" Quick Connect	2
2	V3150	WS1 Split Ring	2
3	V3105	O-Ring 215	2
4	V3629LF	WS1 Ftg 1" Brass SharkBite LF	2

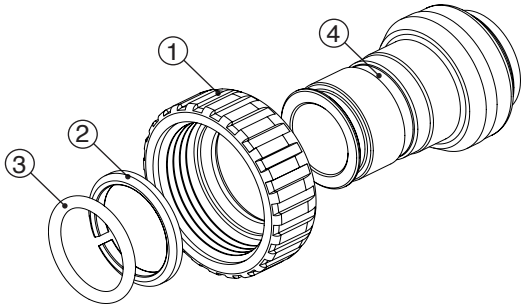

Form No. V3115-36LF • 9/21/2021

**Clack Order No. V3007-13LF**

**Description: WS1 Fitting 1" Brass SharkBite LF Assembly**

Drawing No.	Order No.	Description	Quantity
1	V3151	WS1 Nut 1" Quick Connect	2
2	V3150	WS1 Split Ring	2
3	V3105	O-Ring 215	2
4	V3629LF	WS1 Ftg 1" Brass SharkBite LF	2

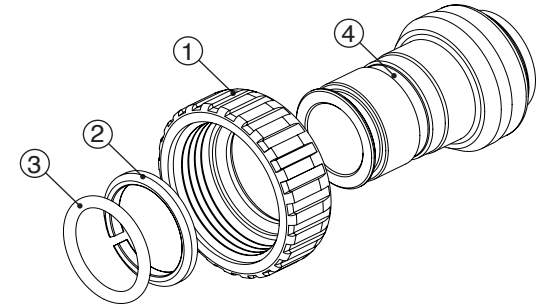

Form No. V3115-36LF • 9/21/2021

**Clack Order No. V3007-13LF**

**Description: WS1 Fitting 1" Brass SharkBite LF Assembly**

Drawing No.	Order No.	Description	Quantity
1	V3151	WS1 Nut 1" Quick Connect	2
2	V3150	WS1 Split Ring	2
3	V3105	O-Ring 215	2
4	V3629LF	WS1 Ftg 1" Brass SharkBite LF	2

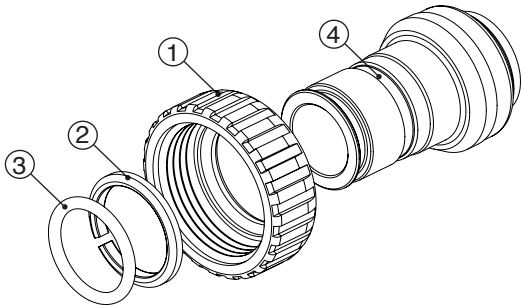

Form No. V3115-36LF • 9/21/2021

**Clack Order No. V3007-13LF**

**Description: WS1 Fitting 1" Brass SharkBite LF Assembly**

Drawing No.	Order No.	Description	Quantity
1	V3151	WS1 Nut 1" Quick Connect	2
2	V3150	WS1 Split Ring	2
3	V3105	O-Ring 215	2
4	V3629LF	WS1 Ftg 1" Brass SharkBite LF	2

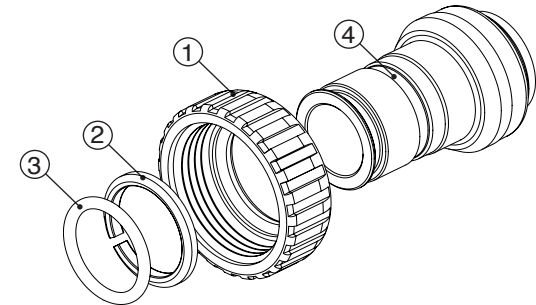

Form No. V3115-36LF • 9/21/2021

## Clack Order No. V3007-13LF

### Description: WS1 Fitting 1" Brass SharkBite LF Assembly

HYDROCARBONS SUCH AS VASELINE®, PETROLEUM JELLY, KEROSENE, BENZENE, GASOLINE, ETC., WILL DAMAGE PRODUCTS THAT CONTAIN O-RINGS OR PLASTIC COMPONENTS. EXPOSURE TO SUCH HYDROCARBONS MAY CAUSE THE PRODUCTS TO LEAK. DO NOT USE CLACK CONTROL VALVE PRODUCT(S) ON WATER SUPPLIES THAT CONTAIN HYDROCARBONS SUCH AS KEROSENE, BENZENE, GASOLINE, ETC.

#### Fitting Installation Instructions

- Installation fittings are designed to accommodate minor plumbing misalignments, but are not designed to support the weight of a system or the plumbing.
- The SharkBite® fittings can only be used with pipe/tubing certified to the following specifications: PEX (ASTM F876, CSA B137.5), Copper (ASTM B88), CPVC (ASTM D2846, CSA B137.6).
- The SharkBite® fittings have an integral Tube Support Liner that is effective in supporting PEX tubing to ensure the o-ring seals correctly on the outside of the PEX tubing. The Tube Support Liner is not required for use with CPVC and copper tubing; however these two types of tubing fit over the Tube Support Liner easily and hold it against the tube stop.
- Follow SharkBite® installation instructions on [www.cashacme.com/prod\\_literature.php](http://www.cashacme.com/prod_literature.php) to install fittings. Use SharkBite® depth gauge to ensure proper depth of tubing. Installation instructions also describe removal of Tube Support Liner and disassembly instructions.
- Slide nut on first, then the split ring and o-ring.
- Hand tighten nut only.

**NOTE:** This fitting has been verified by the Water Quality Association to contain less than 0.25% lead content. These fittings suitability for use in California have not been determined under California Proposition 65 and therefore these fittings should not be installed in California.

SharkBite® is a registered trademark of Reliance Worldwide Corporation, Cash Acme Division



This product is Tested and Certified by NSF International against NSF/ANSI 44 for material and structural integrity requirements and NSF/ANSI/CAN Standard 61 for material requirements. Certified to NSF/ANSI/CAN 372.

Form No. V3115-36LF • 9/21/2021

## Clack Order No. V3007-13LF

### Description: WS1 Fitting 1" Brass SharkBite LF Assembly

HYDROCARBONS SUCH AS VASELINE®, PETROLEUM JELLY, KEROSENE, BENZENE, GASOLINE, ETC., WILL DAMAGE PRODUCTS THAT CONTAIN O-RINGS OR PLASTIC COMPONENTS. EXPOSURE TO SUCH HYDROCARBONS MAY CAUSE THE PRODUCTS TO LEAK. DO NOT USE CLACK CONTROL VALVE PRODUCT(S) ON WATER SUPPLIES THAT CONTAIN HYDROCARBONS SUCH AS KEROSENE, BENZENE, GASOLINE, ETC.

#### Fitting Installation Instructions

- Installation fittings are designed to accommodate minor plumbing misalignments, but are not designed to support the weight of a system or the plumbing.
- The SharkBite® fittings can only be used with pipe/tubing certified to the following specifications: PEX (ASTM F876, CSA B137.5), Copper (ASTM B88), CPVC (ASTM D2846, CSA B137.6).
- The SharkBite® fittings have an integral Tube Support Liner that is effective in supporting PEX tubing to ensure the o-ring seals correctly on the outside of the PEX tubing. The Tube Support Liner is not required for use with CPVC and copper tubing; however these two types of tubing fit over the Tube Support Liner easily and hold it against the tube stop.
- Follow SharkBite® installation instructions on [www.cashacme.com/prod\\_literature.php](http://www.cashacme.com/prod_literature.php) to install fittings. Use SharkBite® depth gauge to ensure proper depth of tubing. Installation instructions also describe removal of Tube Support Liner and disassembly instructions.
- Slide nut on first, then the split ring and o-ring.
- Hand tighten nut only.

**NOTE:** This fitting has been verified by the Water Quality Association to contain less than 0.25% lead content. These fittings suitability for use in California have not been determined under California Proposition 65 and therefore these fittings should not be installed in California.

SharkBite® is a registered trademark of Reliance Worldwide Corporation, Cash Acme Division



This product is Tested and Certified by NSF International against NSF/ANSI 44 for material and structural integrity requirements and NSF/ANSI/CAN Standard 61 for material requirements. Certified to NSF/ANSI/CAN 372.

Form No. V3115-36LF • 9/21/2021

## Clack Order No. V3007-13LF

### Description: WS1 Fitting 1" Brass SharkBite LF Assembly

HYDROCARBONS SUCH AS VASELINE®, PETROLEUM JELLY, KEROSENE, BENZENE, GASOLINE, ETC., WILL DAMAGE PRODUCTS THAT CONTAIN O-RINGS OR PLASTIC COMPONENTS. EXPOSURE TO SUCH HYDROCARBONS MAY CAUSE THE PRODUCTS TO LEAK. DO NOT USE CLACK CONTROL VALVE PRODUCT(S) ON WATER SUPPLIES THAT CONTAIN HYDROCARBONS SUCH AS KEROSENE, BENZENE, GASOLINE, ETC.

#### Fitting Installation Instructions

- Installation fittings are designed to accommodate minor plumbing misalignments, but are not designed to support the weight of a system or the plumbing.
- The SharkBite® fittings can only be used with pipe/tubing certified to the following specifications: PEX (ASTM F876, CSA B137.5), Copper (ASTM B88), CPVC (ASTM D2846, CSA B137.6).
- The SharkBite® fittings have an integral Tube Support Liner that is effective in supporting PEX tubing to ensure the o-ring seals correctly on the outside of the PEX tubing. The Tube Support Liner is not required for use with CPVC and copper tubing; however these two types of tubing fit over the Tube Support Liner easily and hold it against the tube stop.
- Follow SharkBite® installation instructions on [www.cashacme.com/prod\\_literature.php](http://www.cashacme.com/prod_literature.php) to install fittings. Use SharkBite® depth gauge to ensure proper depth of tubing. Installation instructions also describe removal of Tube Support Liner and disassembly instructions.
- Slide nut on first, then the split ring and o-ring.
- Hand tighten nut only.

**NOTE:** This fitting has been verified by the Water Quality Association to contain less than 0.25% lead content. These fittings suitability for use in California have not been determined under California Proposition 65 and therefore these fittings should not be installed in California.

SharkBite® is a registered trademark of Reliance Worldwide Corporation, Cash Acme Division



This product is Tested and Certified by NSF International against NSF/ANSI 44 for material and structural integrity requirements and NSF/ANSI/CAN Standard 61 for material requirements. Certified to NSF/ANSI/CAN 372.

Form No. V3115-36LF • 9/21/2021

## Clack Order No. V3007-13LF

### Description: WS1 Fitting 1" Brass SharkBite LF Assembly

HYDROCARBONS SUCH AS VASELINE®, PETROLEUM JELLY, KEROSENE, BENZENE, GASOLINE, ETC., WILL DAMAGE PRODUCTS THAT CONTAIN O-RINGS OR PLASTIC COMPONENTS. EXPOSURE TO SUCH HYDROCARBONS MAY CAUSE THE PRODUCTS TO LEAK. DO NOT USE CLACK CONTROL VALVE PRODUCT(S) ON WATER SUPPLIES THAT CONTAIN HYDROCARBONS SUCH AS KEROSENE, BENZENE, GASOLINE, ETC.

#### Fitting Installation Instructions

- Installation fittings are designed to accommodate minor plumbing misalignments, but are not designed to support the weight of a system or the plumbing.
- The SharkBite® fittings can only be used with pipe/tubing certified to the following specifications: PEX (ASTM F876, CSA B137.5), Copper (ASTM B88), CPVC (ASTM D2846, CSA B137.6).
- The SharkBite® fittings have an integral Tube Support Liner that is effective in supporting PEX tubing to ensure the o-ring seals correctly on the outside of the PEX tubing. The Tube Support Liner is not required for use with CPVC and copper tubing; however these two types of tubing fit over the Tube Support Liner easily and hold it against the tube stop.
- Follow SharkBite® installation instructions on [www.cashacme.com/prod\\_literature.php](http://www.cashacme.com/prod_literature.php) to install fittings. Use SharkBite® depth gauge to ensure proper depth of tubing. Installation instructions also describe removal of Tube Support Liner and disassembly instructions.
- Slide nut on first, then the split ring and o-ring.
- Hand tighten nut only.

**NOTE:** This fitting has been verified by the Water Quality Association to contain less than 0.25% lead content. These fittings suitability for use in California have not been determined under California Proposition 65 and therefore these fittings should not be installed in California.

SharkBite® is a registered trademark of Reliance Worldwide Corporation, Cash Acme Division



This product is Tested and Certified by NSF International against NSF/ANSI 44 for material and structural integrity requirements and NSF/ANSI/CAN Standard 61 for material requirements. Certified to NSF/ANSI/CAN 372.

Form No. V3115-36LF • 9/21/2021