

Order No. V3007-15
Description: WS1 FTG 3/4 JG QC 90 ASY

Drawing No.	Order No.	Description	Quantity
1	V3105	O-RING 215	2
2	V3150	WS1 SPLIT RING	2
3	V3151	WS1 NUT 1 QC	2
4	V3790	WS1 ELBOW 3/4 QC W/STEM	2

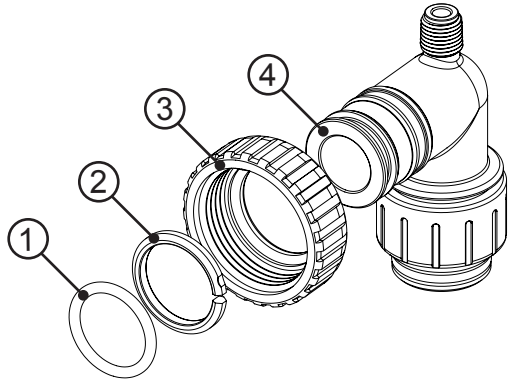

Form No. V3115-40 • 9/21/2021

Order No. V3007-15
Description: WS1 FTG 3/4 JG QC 90 ASY

Drawing No.	Order No.	Description	Quantity
1	V3105	O-RING 215	2
2	V3150	WS1 SPLIT RING	2
3	V3151	WS1 NUT 1 QC	2
4	V3790	WS1 ELBOW 3/4 QC W/STEM	2

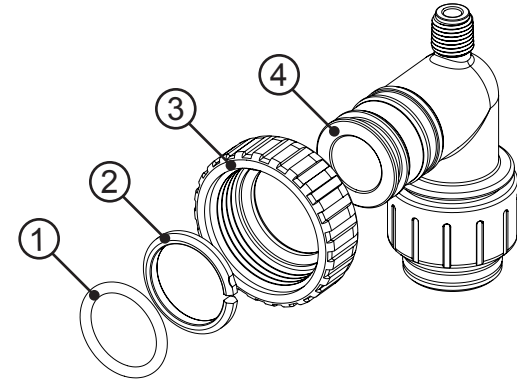

Form No. V3115-40 • 9/21/2021

Order No. V3007-15
Description: WS1 FTG 3/4 JG QC 90 ASY

Drawing No.	Order No.	Description	Quantity
1	V3105	O-RING 215	2
2	V3150	WS1 SPLIT RING	2
3	V3151	WS1 NUT 1 QC	2
4	V3790	WS1 ELBOW 3/4 QC W/STEM	2

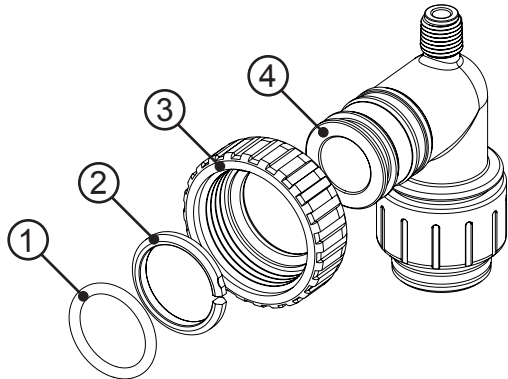

Form No. V3115-40 • 9/21/2021

Order No. V3007-15
Description: WS1 FTG 3/4 JG QC 90 ASY

Drawing No.	Order No.	Description	Quantity
1	V3105	O-RING 215	2
2	V3150	WS1 SPLIT RING	2
3	V3151	WS1 NUT 1 QC	2
4	V3790	WS1 ELBOW 3/4 QC W/STEM	2

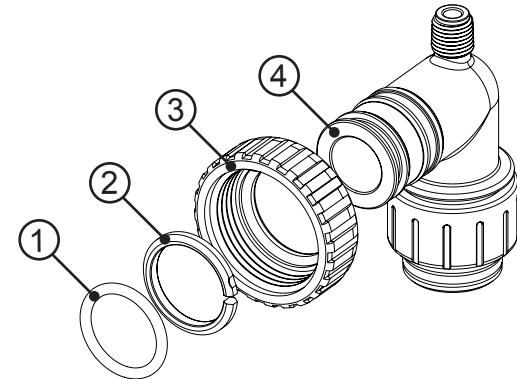

Form No. V3115-40 • 9/21/2021

Order No. V3007-15
Description: WS1 FTG ¾ JG QC 90 ASY

HYDROCARBONS SUCH AS VASELINE®, PETROLEUM JELLY, KEROSENE, BENZENE, GASOLINE, ETC., WILL DAMAGE PRODUCTS THAT CONTAIN O-RINGS OR PLASTIC COMPONENTS. EXPOSURE TO SUCH HYDROCARBONS MAY CAUSE THE PRODUCTS TO LEAK. DO NOT USE CLACK CONTROL VALVE PRODUCT(S) ON WATER SUPPLIES THAT CONTAIN HYDROCARBONS SUCH AS KEROSENE, BENZENE, GASOLINE, ETC.

V3790 is a NC2521 Series fitting manufactured by John Guest LTD and is listed under NSF/ANSI 14. The fitting is compliant with NSF/ANSI 61 and Annex G of NSF/ANSI 61.

Installation Instructions:

- Installation fittings are designed to accommodate minor plumbing misalignments, but are not designed to support the weight of a system or the plumbing.
- JG Speedfit fitting can be used on COPPER, CPVC and PEX in 1" size that is in compliance with ASTM F876, ASTM F877, CSA B137-5 and ASSE1061.
- The Twist & Lock fitting has a collet with stainless steel teeth in it to grip the pipe when fully inserted to the stop in the fitting.
- To prevent damage from occurring to the o-ring and to be sure to make a good connection be sure to have a straight cut, remove all burrs and bevel the end of the pipe to be inserted into the fitting.
- Follow Speedfit installation instructions that you will find at www.johnguest.com
- Slide nut on first, then the split ring and o-ring
- Hand tighten nut only



This product is Tested and Certified by NSF International against NSF/ANSI 44 for material and structural integrity requirements and NSF/ANSI/CAN Standard 61 for material requirements. Certified to NSF/ANSI/CAN 372.

Form No. V3115-40 • 9/21/2021

Order No. V3007-15
Description: WS1 FTG ¾ JG QC 90 ASY

HYDROCARBONS SUCH AS VASELINE®, PETROLEUM JELLY, KEROSENE, BENZENE, GASOLINE, ETC., WILL DAMAGE PRODUCTS THAT CONTAIN O-RINGS OR PLASTIC COMPONENTS. EXPOSURE TO SUCH HYDROCARBONS MAY CAUSE THE PRODUCTS TO LEAK. DO NOT USE CLACK CONTROL VALVE PRODUCT(S) ON WATER SUPPLIES THAT CONTAIN HYDROCARBONS SUCH AS KEROSENE, BENZENE, GASOLINE, ETC.

V3790 is a NC2521 Series fitting manufactured by John Guest LTD and is listed under NSF/ANSI 14. The fitting is compliant with NSF/ANSI 61 and Annex G of NSF/ANSI 61.

Installation Instructions:

- Installation fittings are designed to accommodate minor plumbing misalignments, but are not designed to support the weight of a system or the plumbing.
- JG Speedfit fitting can be used on COPPER, CPVC and PEX in 1" size that is in compliance with ASTM F876, ASTM F877, CSA B137-5 and ASSE1061.
- The Twist & Lock fitting has a collet with stainless steel teeth in it to grip the pipe when fully inserted to the stop in the fitting.
- To prevent damage from occurring to the o-ring and to be sure to make a good connection be sure to have a straight cut, remove all burrs and bevel the end of the pipe to be inserted into the fitting.
- Follow Speedfit installation instructions that you will find at www.johnguest.com
- Slide nut on first, then the split ring and o-ring
- Hand tighten nut only



This product is Tested and Certified by NSF International against NSF/ANSI 44 for material and structural integrity requirements and NSF/ANSI/CAN Standard 61 for material requirements. Certified to NSF/ANSI/CAN 372.

Form No. V3115-40 • 9/21/2021

Order No. V3007-15
Description: WS1 FTG ¾ JG QC 90 ASY

HYDROCARBONS SUCH AS VASELINE®, PETROLEUM JELLY, KEROSENE, BENZENE, GASOLINE, ETC., WILL DAMAGE PRODUCTS THAT CONTAIN O-RINGS OR PLASTIC COMPONENTS. EXPOSURE TO SUCH HYDROCARBONS MAY CAUSE THE PRODUCTS TO LEAK. DO NOT USE CLACK CONTROL VALVE PRODUCT(S) ON WATER SUPPLIES THAT CONTAIN HYDROCARBONS SUCH AS KEROSENE, BENZENE, GASOLINE, ETC.

V3790 is a NC2521 Series fitting manufactured by John Guest LTD and is listed under NSF/ANSI 14. The fitting is compliant with NSF/ANSI 61 and Annex G of NSF/ANSI 61.

Installation Instructions:

- Installation fittings are designed to accommodate minor plumbing misalignments, but are not designed to support the weight of a system or the plumbing.
- JG Speedfit fitting can be used on COPPER, CPVC and PEX in 1" size that is in compliance with ASTM F876, ASTM F877, CSA B137-5 and ASSE1061.
- The Twist & Lock fitting has a collet with stainless steel teeth in it to grip the pipe when fully inserted to the stop in the fitting.
- To prevent damage from occurring to the o-ring and to be sure to make a good connection be sure to have a straight cut, remove all burrs and bevel the end of the pipe to be inserted into the fitting.
- Follow Speedfit installation instructions that you will find at www.johnguest.com
- Slide nut on first, then the split ring and o-ring
- Hand tighten nut only



This product is Tested and Certified by NSF International against NSF/ANSI 44 for material and structural integrity requirements and NSF/ANSI/CAN Standard 61 for material requirements. Certified to NSF/ANSI/CAN 372.

Form No. V3115-40 • 9/21/2021

Order No. V3007-15
Description: WS1 FTG ¾ JG QC 90 ASY

HYDROCARBONS SUCH AS VASELINE®, PETROLEUM JELLY, KEROSENE, BENZENE, GASOLINE, ETC., WILL DAMAGE PRODUCTS THAT CONTAIN O-RINGS OR PLASTIC COMPONENTS. EXPOSURE TO SUCH HYDROCARBONS MAY CAUSE THE PRODUCTS TO LEAK. DO NOT USE CLACK CONTROL VALVE PRODUCT(S) ON WATER SUPPLIES THAT CONTAIN HYDROCARBONS SUCH AS KEROSENE, BENZENE, GASOLINE, ETC.

V3790 is a NC2521 Series fitting manufactured by John Guest LTD and is listed under NSF/ANSI 14. The fitting is compliant with NSF/ANSI 61 and Annex G of NSF/ANSI 61.

Installation Instructions:

- Installation fittings are designed to accommodate minor plumbing misalignments, but are not designed to support the weight of a system or the plumbing.
- JG Speedfit fitting can be used on COPPER, CPVC and PEX in 1" size that is in compliance with ASTM F876, ASTM F877, CSA B137-5 and ASSE1061.
- The Twist & Lock fitting has a collet with stainless steel teeth in it to grip the pipe when fully inserted to the stop in the fitting.
- To prevent damage from occurring to the o-ring and to be sure to make a good connection be sure to have a straight cut, remove all burrs and bevel the end of the pipe to be inserted into the fitting.
- Follow Speedfit installation instructions that you will find at www.johnguest.com
- Slide nut on first, then the split ring and o-ring
- Hand tighten nut only



This product is Tested and Certified by NSF International against NSF/ANSI 44 for material and structural integrity requirements and NSF/ANSI/CAN Standard 61 for material requirements. Certified to NSF/ANSI/CAN 372.

Form No. V3115-40 • 9/21/2021