

Order No. V3805
Description: STRAIN RELIEF COVER KIT

Drawing No.	Order No.	Description	Quantity
1	V3772	WS STRAIN RELIEF CVR BACKPLATE	1
2	V3804	SCREW 6X1/2PHPN T-25 SS	1

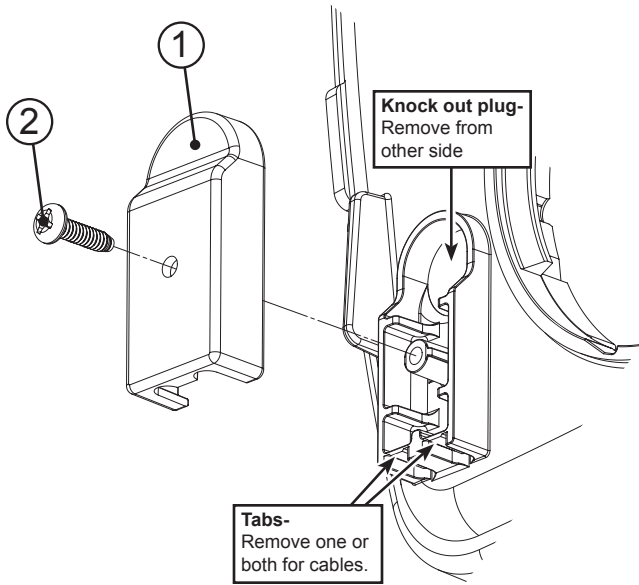

Form No. V3115-42

9/1/2009

Order No. V3805
Description: STRAIN RELIEF COVER KIT

Drawing No.	Order No.	Description	Quantity
1	V3772	WS STRAIN RELIEF CVR BACKPLATE	1
2	V3804	SCREW 6X1/2PHPN T-25 SS	1

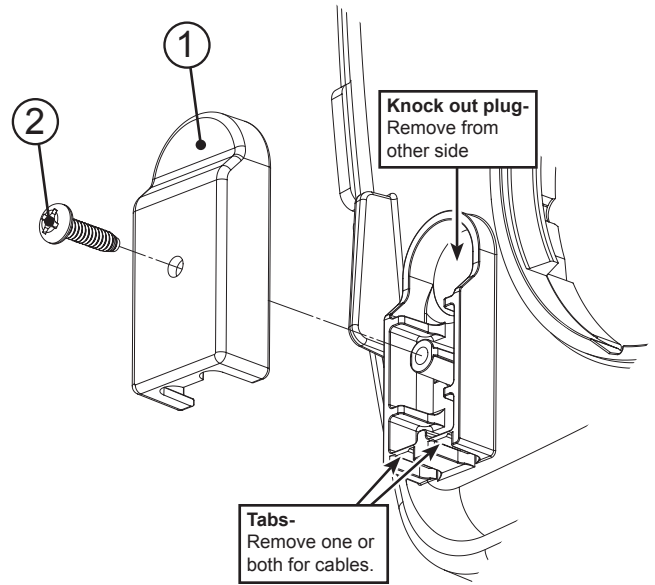

Form No. V3115-42

9/1/2009

Order No. V3805
Description: STRAIN RELIEF COVER KIT

Drawing No.	Order No.	Description	Quantity
1	V3772	WS STRAIN RELIEF CVR BACKPLATE	1
2	V3804	SCREW 6X1/2PHPN T-25 SS	1

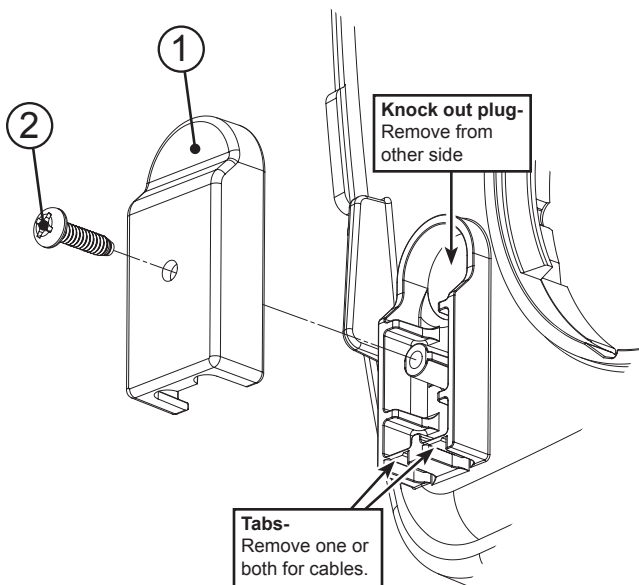

Form No. V3115-42

9/1/2009

Order No. V3805
Description: STRAIN RELIEF COVER KIT

Drawing No.	Order No.	Description	Quantity
1	V3772	WS STRAIN RELIEF CVR BACKPLATE	1
2	V3804	SCREW 6X1/2PHPN T-25 SS	1

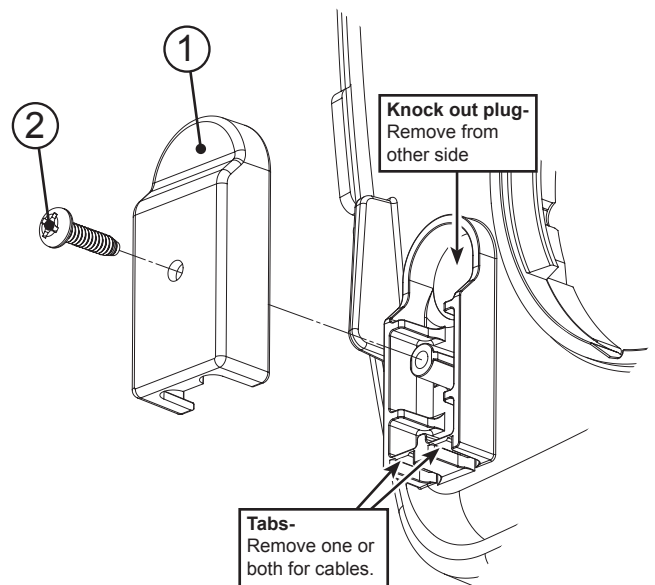

Form No. V3115-42

9/1/2009

Order No. V3805**Description: STRAIN RELIEF COVER KIT****Instructions:**

1. Remove valve cover and drive bracket assembly.
2. From the valve cover side, use a punch and hammer to remove the knock out plug.
3. Smooth the edge of the hole if needed.
4. Use pliers to remove one or both tabs as needed.
5. Run cable(s) through the strain relief feature on the back plate.
6. Reinstall the drive bracket assembly and connect the cables. Adjust cable length if necessary. Do not let the cables come in contact with the drive gear assembly.
7. Install strain relief cover and secure using screw.

Form No. V3115-42

9/1/2009

Order No. V3805**Description: STRAIN RELIEF COVER KIT****Instructions:**

1. Remove valve cover and drive bracket assembly.
2. From the valve cover side, use a punch and hammer to remove the knock out plug.
3. Smooth the edge of the hole if needed.
4. Use pliers to remove one or both tabs as needed.
5. Run cable(s) through the strain relief feature on the back plate.
6. Reinstall the drive bracket assembly and connect the cables. Adjust cable length if necessary. Do not let the cables come in contact with the drive gear assembly.
7. Install strain relief cover and secure using screw.

Form No. V3115-42

9/1/2009

Order No. V3805**Description: STRAIN RELIEF COVER KIT****Instructions:**

1. Remove valve cover and drive bracket assembly.
2. From the valve cover side, use a punch and hammer to remove the knock out plug.
3. Smooth the edge of the hole if needed.
4. Use pliers to remove one or both tabs as needed.
5. Run cable(s) through the strain relief feature on the back plate.
6. Reinstall the drive bracket assembly and connect the cables. Adjust cable length if necessary. Do not let the cables come in contact with the drive gear assembly.
7. Install strain relief cover and secure using screw.

Form No. V3115-42

9/1/2009

Order No. V3805**Description: STRAIN RELIEF COVER KIT****Instructions:**

1. Remove valve cover and drive bracket assembly.
2. From the valve cover side, use a punch and hammer to remove the knock out plug.
3. Smooth the edge of the hole if needed.
4. Use pliers to remove one or both tabs as needed.
5. Run cable(s) through the strain relief feature on the back plate.
6. Reinstall the drive bracket assembly and connect the cables. Adjust cable length if necessary. Do not let the cables come in contact with the drive gear assembly.
7. Install strain relief cover and secure using screw.

Form No. V3115-42

9/1/2009