

## Solar Valve or Retrofit Kit Instructions

The solar panel assembly is shipped with a protective cover over the red terminal that connects to the valve. If the protective covering is removed and the solar panel is exposed to sunlight, it will start to produce electricity. If the ends of the wire are touched approximately a 10 volt charge will be delivered. Remove the protective cover and install the wires on the circuit board.

Back plates with a date code older than 6/10 have a feature that needs to be removed so that it does not interfere with the installation of the drive bracket/battery pack. This feature can be removed using a nippers or with a sharp tool (e.g. wood chisel hit with a hammer).

Feature that must be removed.

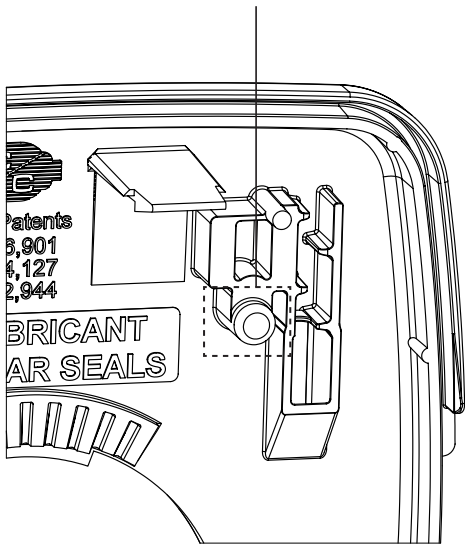

Feature removed.

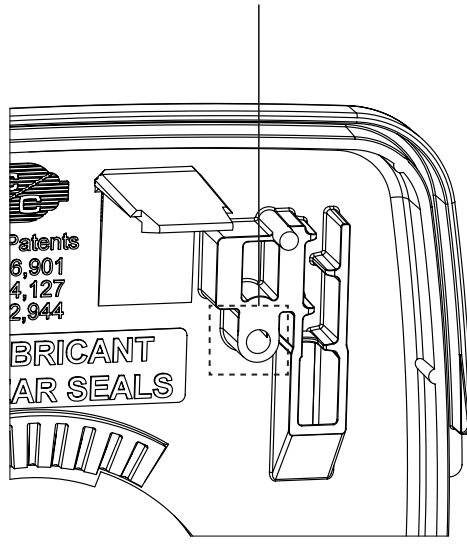

Feature that must be removed.

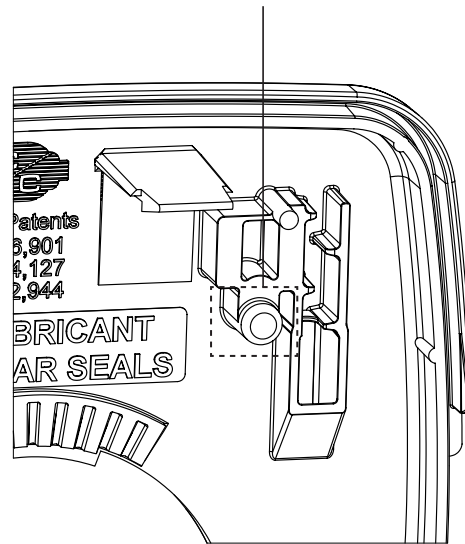

Feature removed.

